

## Contact Information

Orbichronics can be contacted in the United States via the following methods:

Web:	<a href="http://www.orbichronics.com">http://www.orbichronics.com</a>
Phone:	480-839-4118
Fax:	480-839-3894
Email for Sales:	<a href="mailto:sales@orbichronics.com">sales@orbichronics.com</a>
Email for Support:	<a href="mailto:techsupport@orbichronics.com">techsupport@orbichronics.com</a>
Physical Address:	Orbichronics Corporation 2727 West Ocaso Circle Mesa, AZ 85202 USA

# orbichron® clock

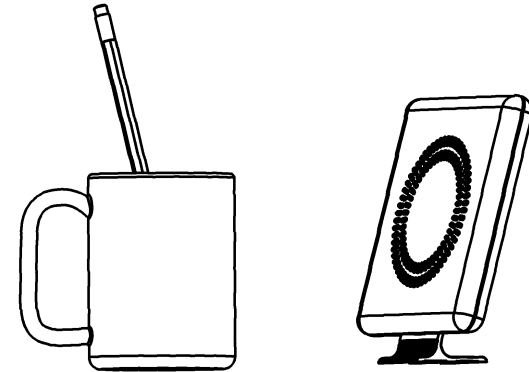

## Index of Figures & Tables

Figure 1 - Clock Settings Mode Display.....	2
Figure 2 - Clock Settings Mode Button Functions .....	2
Figure 3 - Sweep Settings Mode Button Functions .....	3
Figure 4 - Continuous Sweep Mode Button Functions .....	3
Figure 5 - Clock Settings Mode Display.....	4
Figure 6 - Chime Off Window Settings Mode Display.....	5
Figure 7 - Chime Off Window Button Functionality.....	5
Figure 8 - Alarm Settings Mode Display.....	6
Figure 9 - Alarm Settings Button Functionality.....	6
Figure 10—Physical Dimensions.....	8
Table 1 - Interpreting Ship's Bells .....	4
Table 2 - Chime Functionality .....	4

## Operations Guide for ODC-108D-SA Version 1.01

Print Date: November 24, 2001

## Physical Specifications

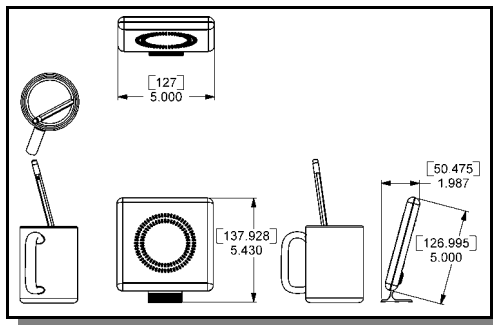

Figure 10—Physical Dimensions

# orbichronics

Orbichron is a registered trademark of Orbichronics Corporation.  
Copyright © 2001 Orbichronics Corporation  
All Rights Reserved

## Table of Contents

Introduction .....	2
Quick Start—Setting the Time .....	2
Sweep Displays .....	3
Chime .....	4
Chime Off Window.....	5
Setting the Alarm .....	5
Other Functionality.....	6
FAQ—Frequently Asked Questions .....	7
Trouble-Shooting .....	7
Contact Information .....	8
Index of Figures & Tables.....	8
Physical Specifications .....	8

## Introduction

Now that you have obtained an **orbichron**® clock, you will naturally want to put it into operation as soon as possible. While exhibiting the elegant simplicity of a traditional analog clock, the workings consist of modern, microprocessor technology, and therefore the intricacies of setup are somewhat, although not terribly, involved. Thank you for your purchase, and may you reap years of enjoyment from this unique timepiece.

## Quick Start – Setting the Time

After locating the **orbichron** clock in a desirable spot, simply plug the supplied wall transformer into a convenient AC outlet, and the adapter's mini-plug into the receptacle at the back of the clock. As the unit performs an initialization and self-testing routine upon powering-up, you will not see any display for a few seconds. After that, you should see the time appear, starting at 12:00:00AM, but you will notice that the hours, minutes, and seconds indicators will blink on and off each successive second with the sweep indicator in continuous motion. Also, at the beginning of each minute that the clock is left in this state, the chime will sound. This flashing and periodic chiming is the *power failure* indication. Pressing any key will clear this display mode.

Locate the *Clock* button on the back of the unit. Press and hold this button...you will see a display similar to the following drawing:

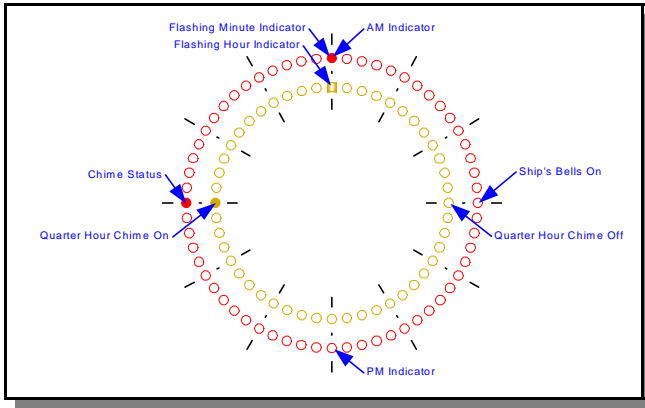

Figure 1 - Clock Settings Mode Display

The hour and minute will be indicated by rapidly flashing LEDs. A solidly lit red LED at the top of the clock indicates AM (see Figure 1). While continuing to hold down the *Clock* button, press the *Hours* button until the proper hour is displayed. Note that with each cycle around the clock face the AM/PM indicator will shift appropriately.

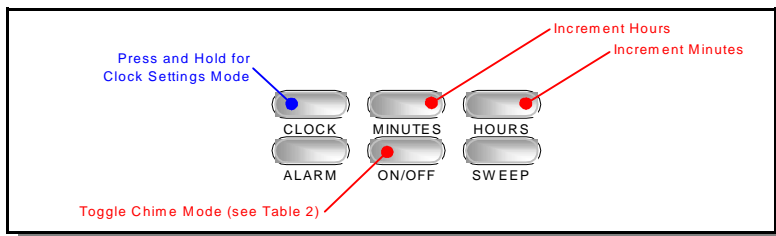

Figure 2 - Clock Settings Mode Button Functions

presses any key. If power does not return until after the sleep mode period is exhausted (possibly up to two hours), the **orbichron** clock will return to the initial start-up defaults, and must be completely reconfigured.

## FAQ - Frequently Asked Questions

Question:	How accurate is the <b>orbichron</b> clock?
Answer:	The <b>orbichron</b> clock is as accurate as the frequency of the AC power it is connected to, which in the United States is extremely accurate. This is due to the exacting requirements of synchronization for sharing on the nationwide power grid.
Question:	There is no "hold" button as there was on the previous <b>orbichron</b> clocks, how do I synchronize the second hand and the sweep?
Answer:	The seconds and sweep displays are reset upon the release of the <i>Minutes</i> button when setting the time. To synchronize with another time source, advance the minute display to one minute prior to the desired position and when you wish to sync the clock, briefly click the <i>Minutes</i> button.
Question:	Is the <b>orbichron</b> clock expensive to operate?
Answer:	No...in fact it should cost less than a dollar per year at today's electric rates.
Question:	Why can't the <b>orbichron</b> clock be battery powered?
Answer:	Although the clock could be run from the internal crystal oscillator time base, it would not be as accurate, and due to the current draw to support the LED display, the life of the batteries would be around 10 to 15 hours. Longer life could be had by limiting the display to a short period of one to two minutes of duration after the user presses a key, but this would defeat the purpose of the clock. And yes, an LCD (liquid-crystal-display) could replace the LEDs, but the dramatic effect would be lost.
Question:	I live in a country where the line frequency is 50Hz and the voltage is 220VAC. Can I operate an <b>orbichron</b> clock by using a voltage adapter?
Answer:	Yes you can! The <b>orbichron</b> clock auto-senses the line frequency and can operate quite effectively from either 50Hz or 60Hz power. The voltage adapter would be a definite requirement if the supplied US style wall transformer were to be used. An alternative 6VAC @ 100mA wall transformer with the appropriate 2.5MM mini-plug could be used, however, you must be aware of the following important note: <b>Do NOT attempt to use a DC (direct current) power supply with the clock!</b>
Question:	I have an older <b>orbichron</b> clock that is very sensitive to power flickers. Is this new design any more tolerant of irregularities and failures?
Answer:	Yes. A major concern during the design phase of the new <b>orbichron</b> clock was to provide for more protection against power spikes, flickers and outages. Check out the section of the Operations Guide under the heading of <i>Other Functionality</i> for a more in-depth description.

## Trouble-Shooting

In the unlikely event that the clock should appear non-functional, simply unplugging and re-powering the clock will not necessarily reset the clock. The clock has an internal watchdog to force a reset if the clock starts *wiggling out*, however, if the watchdog does not catch the problem, an external reset needs to be asserted. The user may first try a *soft reset* by pressing the *Clock*, *Alarm*, *Hours* and *Sweep* buttons simultaneously. Failing that, the clock must be unplugged for at least 2 hours to allow all internal capacitors to drain. If this does not fix the problem, please contact technical support.

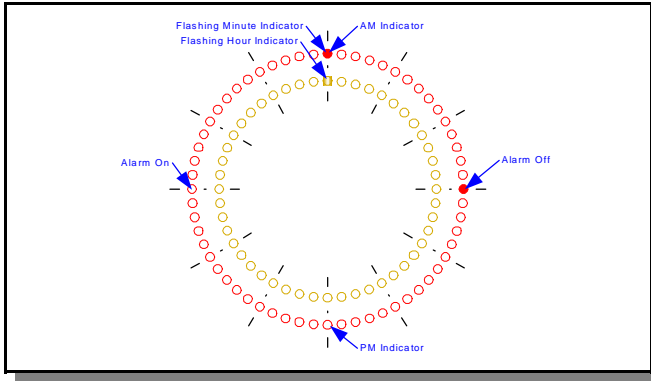

Figure 8 - Alarm Settings Mode Display

To enable or disable the alarm, press and hold the *Alarm* button while keying the *On/Off* button (see Figure 9). Press any key to turn off the chiming once the alarm has sounded.

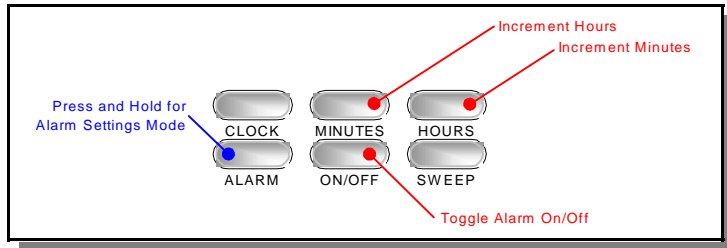

Figure 9 - Alarm Settings Button Functionality

## Other Functionality

For those wanting to display the sweep without the time, you're in luck! Toggle the *On/Off* button by itself to disable and subsequently enable the clock display.

The **orbichron** clock will operate on 50Hz or 60Hz, which means that it can function worldwide, provided that a proper voltage adapter is used. The clock uses the AC line frequency for accuracy, and not the internal crystal oscillator. During the initialization procedure at start-up, the AC power is sampled to determine the frequency.

In the very *likely* event of a power failure, spike or flicker, the **orbichron** clock is very forgiving. Without the need of a backup battery, the clock will continue operation through the use of newly developed capacitor technology. If the power fails completely, the display will blank and no chime will sound while a pseudo sleep mode is entered. In this mode, which will last one minute, the clock will continue counting time from the internal crystal oscillator time base. Should power be restored while in this mode, full operation will be returned with no indication of the blackout. If, after one minute, the power has not been restored, the clock's micro-controller will enter a true sleep mode that is meant to only preserve the configuration settings. When power is restored during true sleep, the clock, after several seconds (possibly as long as 15 seconds), will return to life with all settings intact, but with the time display off by the length of the failure minus the one minute of the pseudo sleep mode. The display will blink to indicate that a power outage occurred, and each minute the chime will sound once. This will continue until the user

After setting the hour, key the *Minutes* button to obtain the proper minute display. The second and sweep display will be reset upon setting the minute. You will note that the hour LED will move as necessary to properly display the correct quarter-hour indication. Release the *Clock* button to resume normal operation.

The **orbichron** clock is now set, and you can step back and enjoy. Note that the following features are defaulted at start-up:

- The sweep display is enabled, and is in the *Continuous Sweep Cycle* mode. This state displays each of the eight individual sweep modes in sequence, changing every fifteen seconds. The individual modes are:
  - Forward Sweep
  - Reverse Sweep
  - One-Second Reversing Sweep
  - Two-Second Reversing Sweep
  - Bounce Sweep
  - Dual Bi-Directional Sweep
  - Quad Bi-Directional Sweep
  - Weighted Pendulum Sweep
- The chime is enabled in a mode that will ding the number of hours on the hour, and a single ding at each of the other quarter-hour intervals.
- The chime *Off Window* is disabled.
- The alarm is disabled, and the alarm time is set to 12:00AM.

## Sweep Displays

The *Continuous Sweep Cycle* mode is defaulted at start-up. To disable the sweep completely, press and hold the *Sweep* button while keying the *On/Off* button. Repeating this procedure will restore the sweep display.

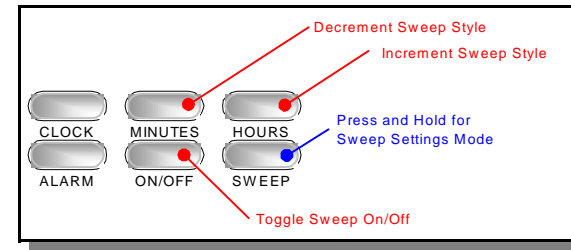

Figure 3 - Sweep Settings Mode Button Functions

Simply changing the sweep style can defeat the *Continuous Sweep Cycle* mode. To do this, press and hold the *Sweep* button while keying either the *Hours* button to step forward through the styles, or the *Minutes* button to step backwards. You will see the display change as you manually step through the sweep styles.

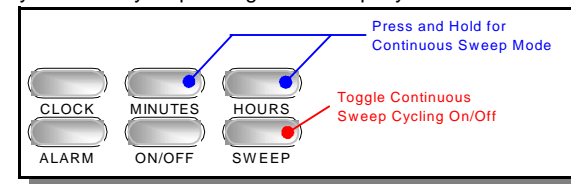

Figure 4 - Continuous Sweep Mode Button Functions

To restore the *Continuous Sweep Cycle* mode, press and hold both the *Hours* and *Minutes* buttons while then keying the *Sweep* button (refer to Figure 4). Note that this can be an alternative method for disabling the continuous cycling mode, as it is a toggle function.

## Chime

The **orbichron** clock has a chime that operates in three modes:

- Normal (default) mode of dinging the number of hours at the hour with an additional ding at the quarter-hour intervals.
- Normal (as above) without the quarter-hour dings.
- Ship's Bells – a pattern of up to eight dings or bells that chime at each half-hour in the continuous four-hour cycle of a traditional nautical chronometer. The bells chime in pairs...for example, eight bells ring as four pairs. The following table indicates how to interpret Ship's Bells:

	12:30	1:00	1:30	2:00	2:30	3:00	3:30	4:00
	4:30	5:00	5:30	6:00	6:30	7:00	7:30	8:00
	8:30	9:00	9:30	10:00	10:30	11:00	11:30	12:00
# Of Bells	1	2	3	4	5	6	7	8

Table 1 - Interpreting Ship's Bells

To alter the chime mode, or to disable it altogether, press and hold the *Clock* button while keying the *On/Off* button (refer to Figure 5) until the desired setting is achieved (see Table 2). The state of the chimes is indicated by the red and amber LEDs at the 9:00 and 3:00 positions.

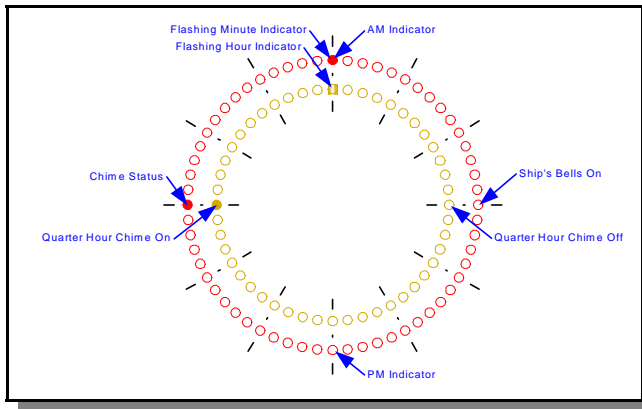

Figure 5 - Clock Settings Mode Display

Chime Function	Chime Status	Quarter Hour Chime On	Quarter Hour Chime Off	Ship's Bells On
On w/Quarter Hour Chime On	●	●	○	○
On w/Quarter Hour Chime Off	●	○	○	○
Ship's Bells On	○	○	○	●
Off	●	○	○	○

Table 2 - Chime Functionality

## Chime Off Window

For those who enjoy the soft chimes of the **orbichron** clock, but don't wish to be disturbed during the night, or some other period of time throughout the day, a *Chime Off Window* has been provided. By default, this window is disabled, and the chime, if enabled, will sound throughout the entire twenty-four hour cycle. To check the status of the *Chime Off Window*, press and hold both the *Clock* and *Alarm* buttons. Initially, the display should be blank, indicating that the window is off. To enable the *Chime Off Window*, press and hold both the *Clock* and *Alarm* buttons while simultaneously keying the *On/Off* button. When toggled on, the display will appear as in Figure 6, with one red LED indicating the *Off After Hour* and one amber LED indicating the *On Hour*.

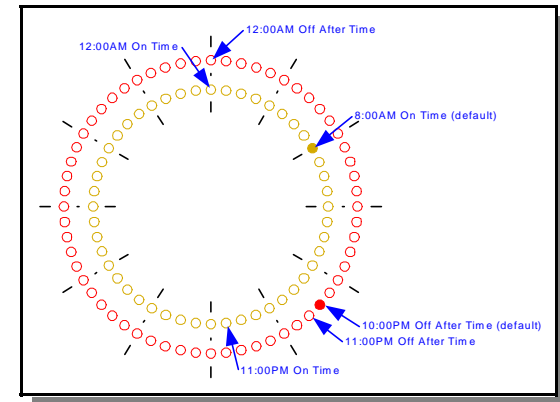

Figure 6 - Chime Off Window Settings Mode Display

The default *Chime Off Window* begins after 10:00PM and ends at 8:00AM. Note that the chime will sound at 10:00PM in the evening and at 8:00AM the following morning, but NOT during the intervening time. To alter the *Off After Time*, or the *On Time* settings, press and hold both the *Clock* and *Alarm* buttons while simultaneously keying the appropriate button (see Figure 7) to cycle through the hourly positions.

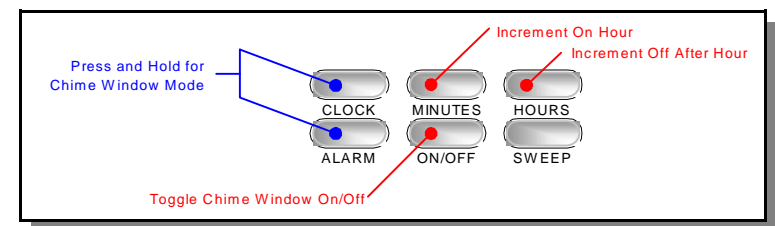

Figure 7 - Chime Off Window Button Functionality

## Setting the Alarm

Although the **orbichron** clock was never intended to be a utilitarian *alarm clock*, that functionality has been provided. Setting the alarm time is very similar to setting the clock time. Press and hold the *Alarm* button to enter the Alarm Settings mode. The display should appear as in Figure 8. As before, the hour and minute indicators will flash to indicate the alarm time, with the top and bottom red LEDs used to display the AM/PM status. Use the *Hours* or *Minutes* button in conjunction with the *Alarm* button to set the alarm time.